



BioenNW – Delivering Bioenergy to North West Europe

Joanna Fletcher, MA BA
BioenNW Project Manager
European Bioenergy Research Institute
Aston University
Email: j.fletcher@aston.ac.uk



BioenNW – Delivering Bioenergy to North West Europe



- **BioenNW – EU Strategic Initiative**
- **Partnership**
- **Work Programme and Achievements**
- **Next Steps**



BioenNW – Delivering Bioenergy to North West Europe



- **BioenNW: EU Strategic Initiative**
- **Partnership**
- **Work Programme and Achievements**
- **Next Steps**



BioenNW: EU Strategic Initiative



- **Delivering Local Bioenergy to North West Europe**
- **INTERREG IVB NWE project**
- **Approved as Strategic Initiative in April 2010 for 5 years**
- **Total budget: €7,974,128**



BioenNW: EU Strategic Initiative



- BioenNW has strategic thematic and geographic relevance to the European Union
- BioenNW's significant focus is on:
 - Production and consumption of energy from renewable sources**
- BioenNW visibility is maximised by wider exposure across the European Union
- BioenNW enhances the strategic impact of the Interreg Programme



BioenNW: EU Strategic Initiative



- ***EUROPEAN INSTITUTE OF INNOVATION AND TECHNOLOGY
(CLIMATE KIC AND ENERGY KIC)***
- ***INTERREG STRATEGIC INITIATIVES: ARBOR, ENALGAE,***
- ***EUROPEAN NETWORKS: PURPLE, ERRIN, CONVENT OF MAYORS***
- ***BRIEFINGS: EU PARLIAMENT, EU COMMISSION, COMMITTEE OF THE
REGIONS***
- ***EVENTS: GREEN WEEK, ENERGY WEEK, EU BIOMASS CONFERENCE***



BioenNW – Delivering Bioenergy to North West Europe



- BioenNW: EU Strategic Initiative
- Partnership
- Work Programme and Achievements
- Next Steps



BioenNW Partnership



United Kingdom:
Aston University
Birmingham City Council
Birmingham City University
Harper Adams University

Netherlands:
Regio Eindhoven

Belgium:
EUBIA
Cluster TWEED

France:
Maire Des Mureaux
RITTMO Agroenvironnement

Germany:
IZES
KIT

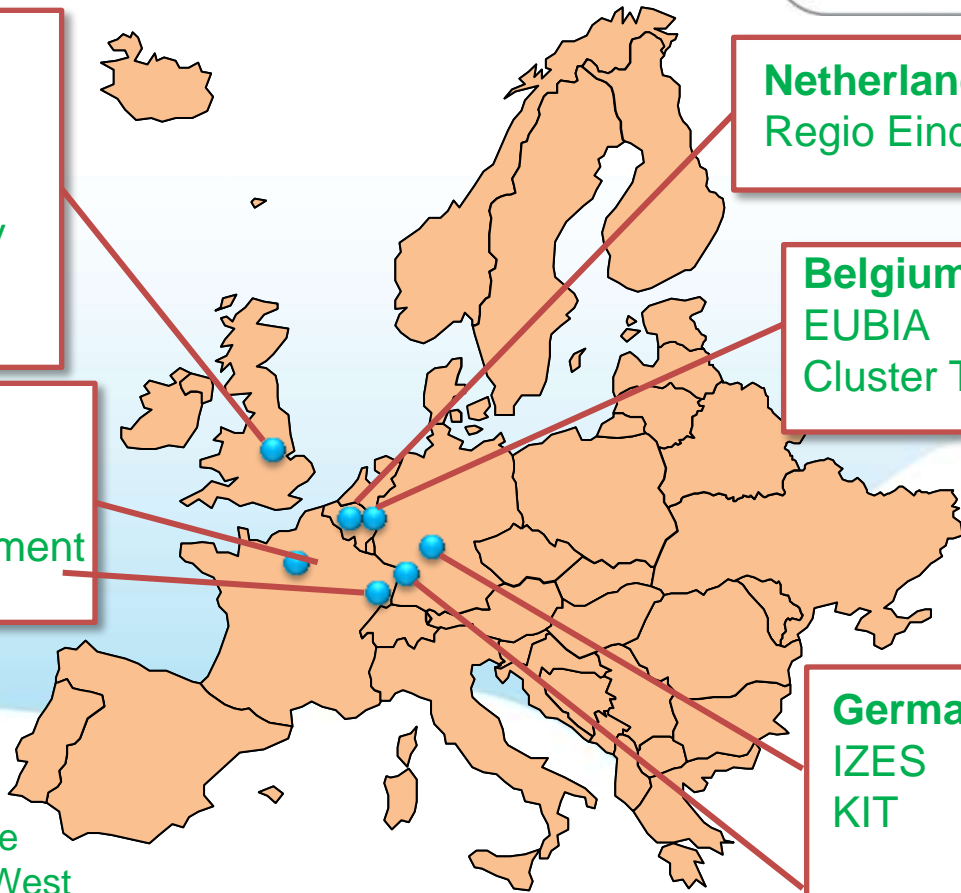

11 Partners:

universities, public authorities, research institutions, private sector, not for profit organisations

5 Countries:

Belgium (Wallonia), Germany (North Rhine Westphalia, Saarland), United Kingdom (West Midlands), Netherlands (Eindhoven), France (Ille de France)



BioenNW Partnership

- **Belfast City Council (UK)**
- **University of Stafford (UK)**
- **Preston City Council (UK)**
- **Birmingham Chamber of Commerce and Industry (UK)**
- **E.ON (UK)**
- **Centre de Recherche Public (LU)**
- **L.e.e.S.à.r.l (LU)**
- **South East Regional Authority (IR)**
- **Strategy and Innovation Division, Sustainable Energy Authority of Ireland (IR)**
- **Organic Waste Systems n.v. (B)**
- **Flandersbio vzw (B)**
- **Xylowatt (B)**
- **European Regions Research and Innovation Network – ERRIN (EU)**
- **Fraunhofer Gesellschaft (DE)**
- **BiomassEnergie (CH)**





BioenNW – Delivering Bioenergy to North West Europe



- Strategic Initiative
- Partnership
- Work Programme and Achievements
- Next Steps



BioenNW: Work Programme



- **Created and operate a pan European network of Bioenergy Support Centres**
- **Developed the Decision Support Tool – investment enhancement tool**
- **Identified locations and prepared development plans for bioenergy power plants**
- **Developed and operate commercial scale technology demonstrators – Pyroformer and Pyrofabs: mobile testing units**



BioenNW: Work Programme Bioenergy Support Centres Network



- ***Pan-European Network of 6 centres with 241 members***
- ***Information Hubs***
- ***Objectives:***
 - promote of bioenergy,
 - support for local bioenergy provision,
 - Engage with policy makers, financial organisations and companies
- ***Services:***
 - advise on investment opportunities,
 - advise on technology relevance,
 - provide access to biomass testing facilities,
 - operate the Decision Support Tool,
 - organise promotional events: regional and international (64 events attended by 5 500 people)



BioenNW: Work Programme Decision Support Tool



Elements:

- GIS database for spatial data
- project design model
- technology integration model
- supply chain model
- risk management model

Requirements analysis:

- Partners and Stakeholders
- Knowledge representation
- Functionality and Design
- Demonstration and feedback
- Validation

DST can be used across NW Europe for:

- assessing the suitability of specific sites for AD & pyrolysis for CHP using biomass
- identifying sites with high project development potential
- preparing project development plans & business

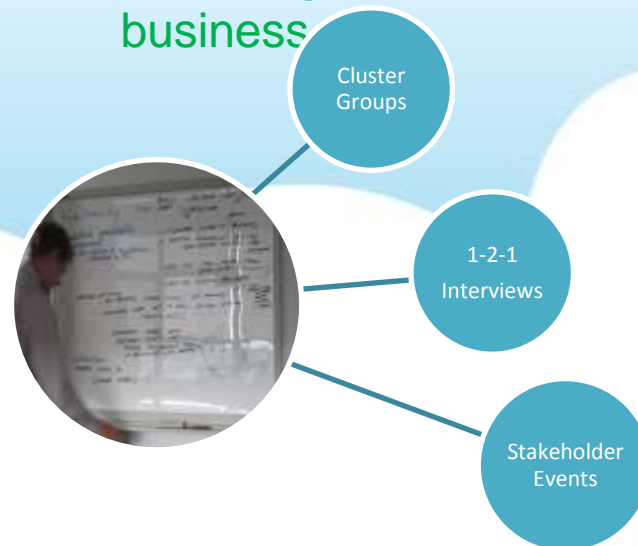



BioenNW: Work Programme Decision Support Tool



Outputs:

Innovative set of tools to support project developers and investors:

- heat & power (CHP sizing) tool
- economic assessment tool
- biomass resource/location optimisation tool
- process pathways tool

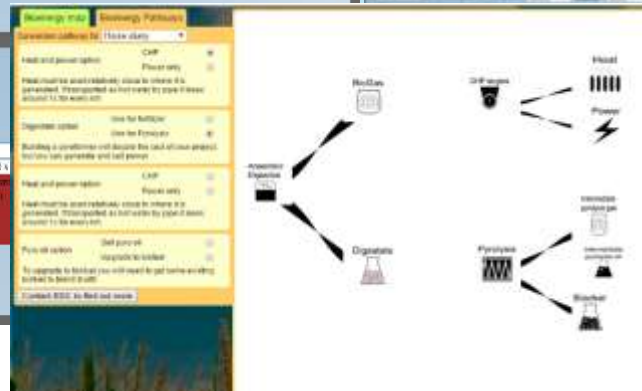
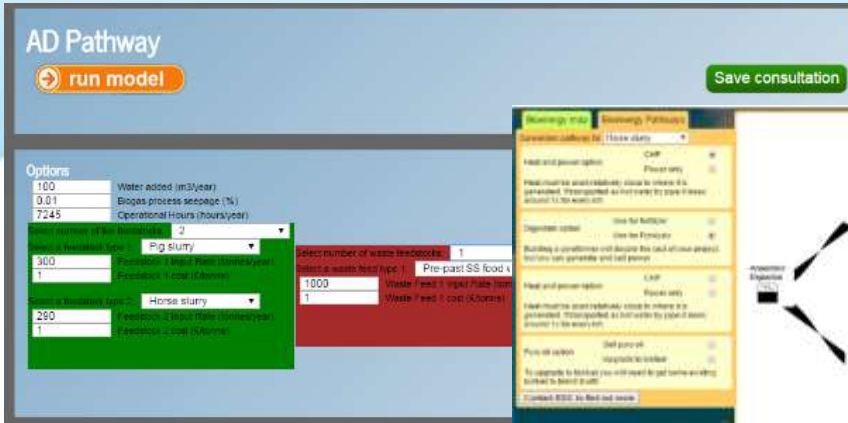



BioenNW: Work Programme

Development plans for bioenergy schemes



- So far the project identified as many as 20 investment opportunities for development of small bioenergy schemes across North West Europe.
- There are further 8 cases in a pipeline.
- The project worked with a variety of stakeholders to create public and private partnerships to transform at least 5 of the identified opportunities into business developments.
- These developments will trigger €30m of private and public sector investment.



BioenNW: Work Programme

List of Development plans



UK bioenergy development plan case studies

- [Birmingham City Council: Kings Heath Nursery](#), Birmingham, UK
- [Brookside Recycled Energy from Waste](#), Telford, Birmingham, UK
- [Harper Adams University](#), Shropshire, UK
- [St Francis Group: Atlas Project](#), Tyseley area, Birmingham, UK
- [South Warwickshire Community Interest Group](#), Warwickshire, West Midlands, UK
- [Cwm Harry Community AD scheme](#), Shropshire, West Midlands, UK

Netherlands bioenergy development plan case studies

- [Surplus manure to create valuable products](#), Eindhoven, Netherlands
- [Upcycling spent mushroom compost](#), Eindhoven, Netherlands
- [Flying on pig manure](#), Breda, Netherlands
- [Sustainable landscapes 4 new energy](#), Groote Heide, Netherlands
- [Peeland biobased economy: closing the loop locally](#), Deurne, Netherlands
- [Pyrolysis on a farm scale](#), North Brabant, Netherlands

Germany bioenergy development plan case studies

- [Dudelbingerhof GmbH: Pyrolysis of digestate](#), Contwig, Stambach, Germany
- [STEAG New Energies GmbH](#), Dresden, Germany

France bioenergy development plan case studies

- [Anaerobic Digestion to treat sewage sludge and fat](#), Les Mureaux, France
- [Aubetin Farm: Anaerobic Digestion Plant](#), Dagny, Seine & Marne County, France
- [Compomar: Pyrolysis & Bio Activated Fuel Reactor](#), Plateau de Saclay, Essonne County, France
- [Equimeth: Anaerobic Digestion Plant](#), Economic Hub Les Renardières, Seine & Marne Co
- [Biomass boiler installation: Mairie les Mureaux](#), Mairie les Mureaux, France

Belgium bioenergy development plan case studies

- [Forem Environnement: Development of AD training](#), Mons, Belgium



BioenNW: Work Programme Technology Demonstrators: Pyroformer



- The Pyroformer™ is an innovative energy-from-waste technology developed by scientists at the European Bioenergy Research Institute (EBRI).
- Designed to be a flexible and scalable technology that can complement other processes and accommodate diverse feedstocks.
- Enables multiple waste streams to be converted into a range of products
- The technology has evolved through a rigorous R&D programme and is now at the cusp of commercialisation.





BioenNW: Work Programme Technology Demonstrators: Plant and Lab Unit



Evolution of the Pyroformer™: EBRI Demonstrator Plant

- 100kg/hour unit built to power EBRI building
- Can be coupled to Gasifier for advanced applications
- Unit produces fuels for 350kW CHP engine
- Provides heat, electricity and cooling for EBRI building
- One of the largest test facilities in the world.



Evolution of the Pyroformer™: New EBRI Testing Unit

- New EBRI facility constructed to accelerate Aston's research on bioenergy
- 20kg/hour test unit in specialist lab for industry feedstock testing
- Used to test feedstocks and optimise production of fuels
- Custom reports prepared for industry customers
- 'Vetting' stage before feedstock can be tested or larger plant





BioenNW: Work Programme Technology Demonstrators: Pyrofabs – mobile testing units



- **Small-scale (20kg/hr) test cells that will be used by BioenNW partners to demonstrate technology and test various local feedstocks. Sourcing biomass locally also significantly reduces the environmental impact of its transportation, further contributing to sustainability**
- Provide 'real-time' performance data, monitoring and analysis
- **Showcase the technology to investors, government and customers across a variety of markets**
- The Pyrofab upgrades waste into two commercial products, oils which can be used for fuel or in chemical production and biochar which is a tradable commodity that can be used to improve soil.
- **The Pyrofab is compact and transportable. When it is commercially available this will allow industry and rural communities to benefit from the bioenergy market by reducing waste management costs for businesses.**



BioenNW: Work Programme Technology Demonstrators: Pyrofab – mobile testing units



Pyrofab BioenNW European Tour

- 24 July – Germany
- 28 August – Sweden
- 7 October – France



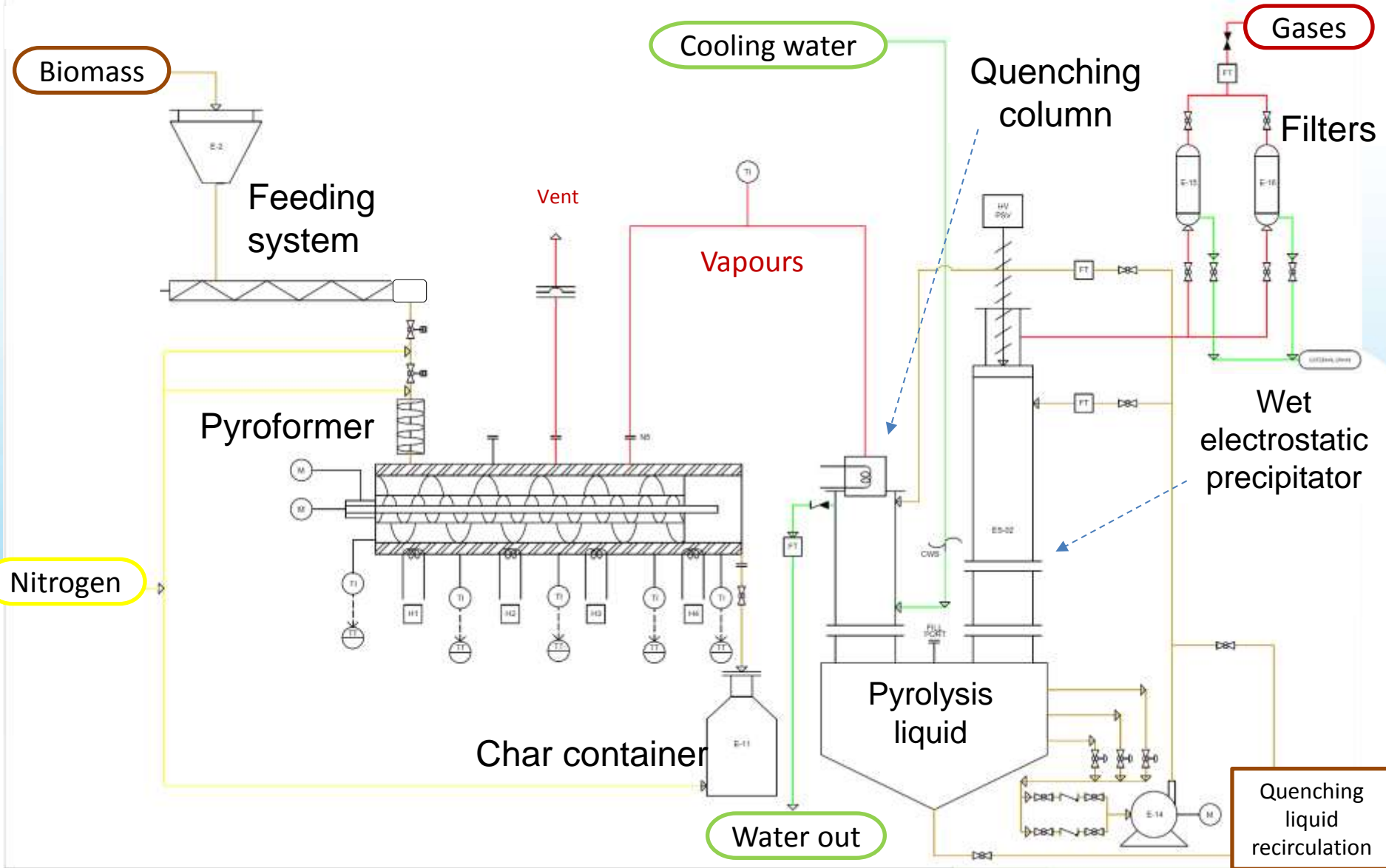



BioenNW: Work Programme Technology Demonstrators: Pyrofabs – mobile testing units

The Pyroformer™ reactor within the Pyrofab

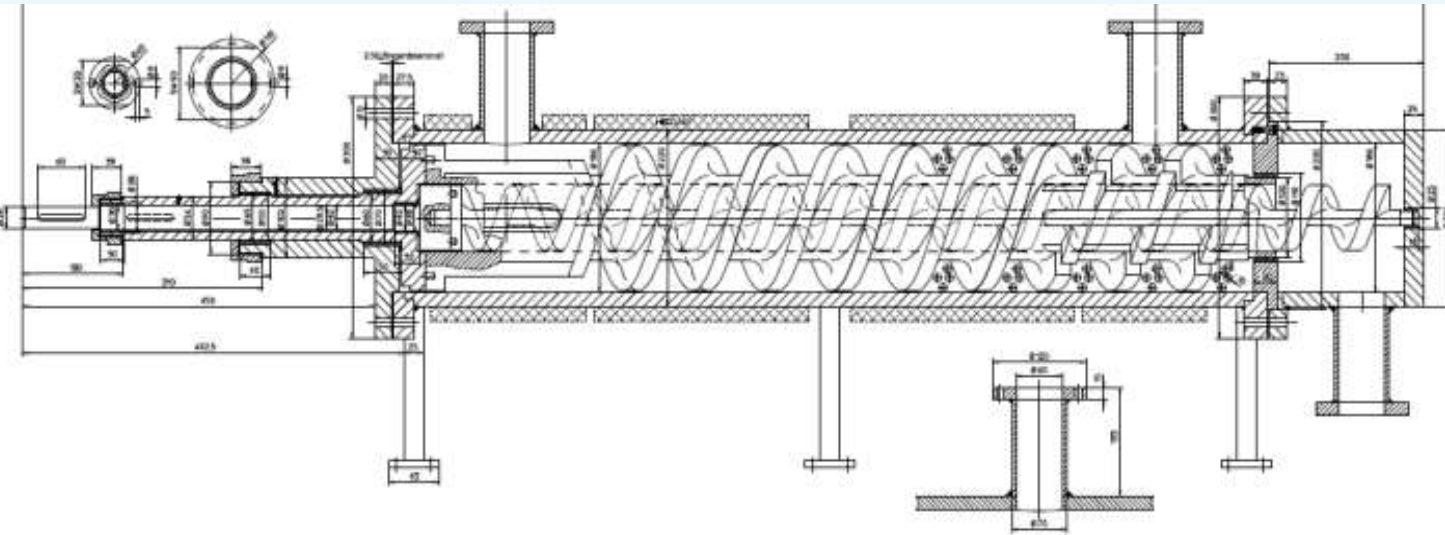

Outer and
inner screws



BioenNW: Work Programme Technology Demonstrators: Pyrofabs – mobile testing units



Feedstock (waste materials) \longrightarrow Products from intermediate pyrolysis

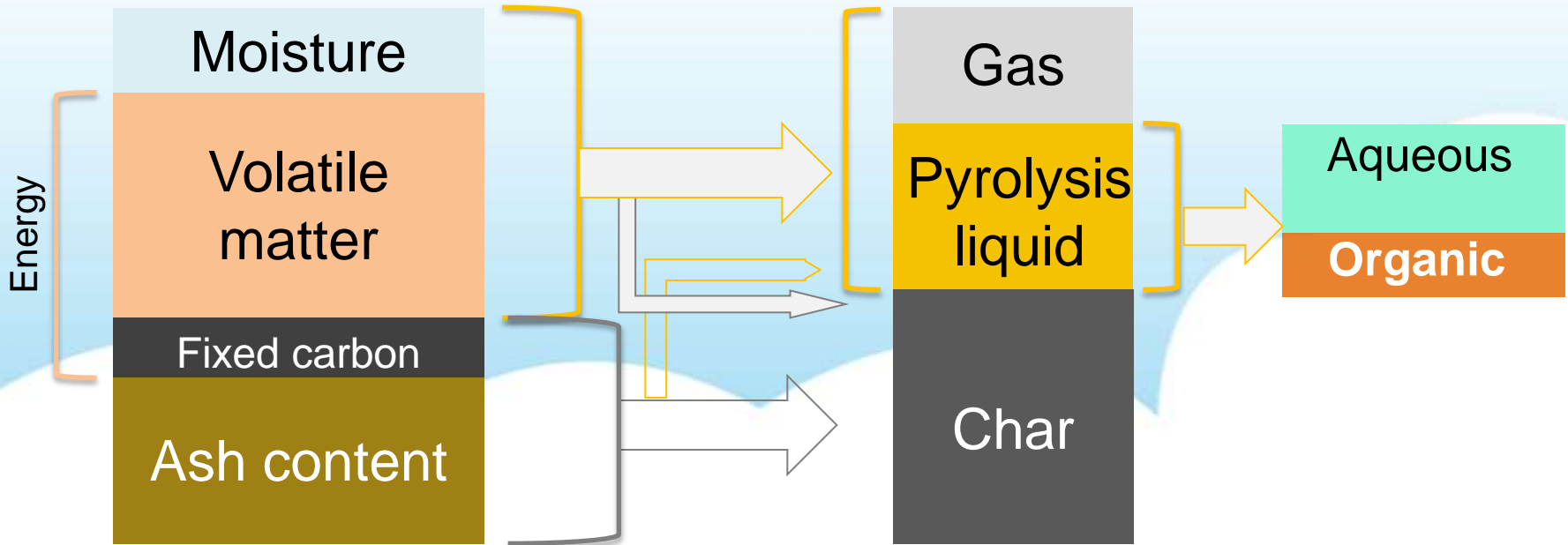



BioenNW: Work Programme Technology Demonstrators: Pyrofabs – mobile testing units



The pyrolysis liquid usually comprises an organic and an aqueous phase



Aqueous phase

Organic phase



BioenNW: Work Programme Technology Demonstrators: Pyrofabs – mobile testing units



Utilisation of the products

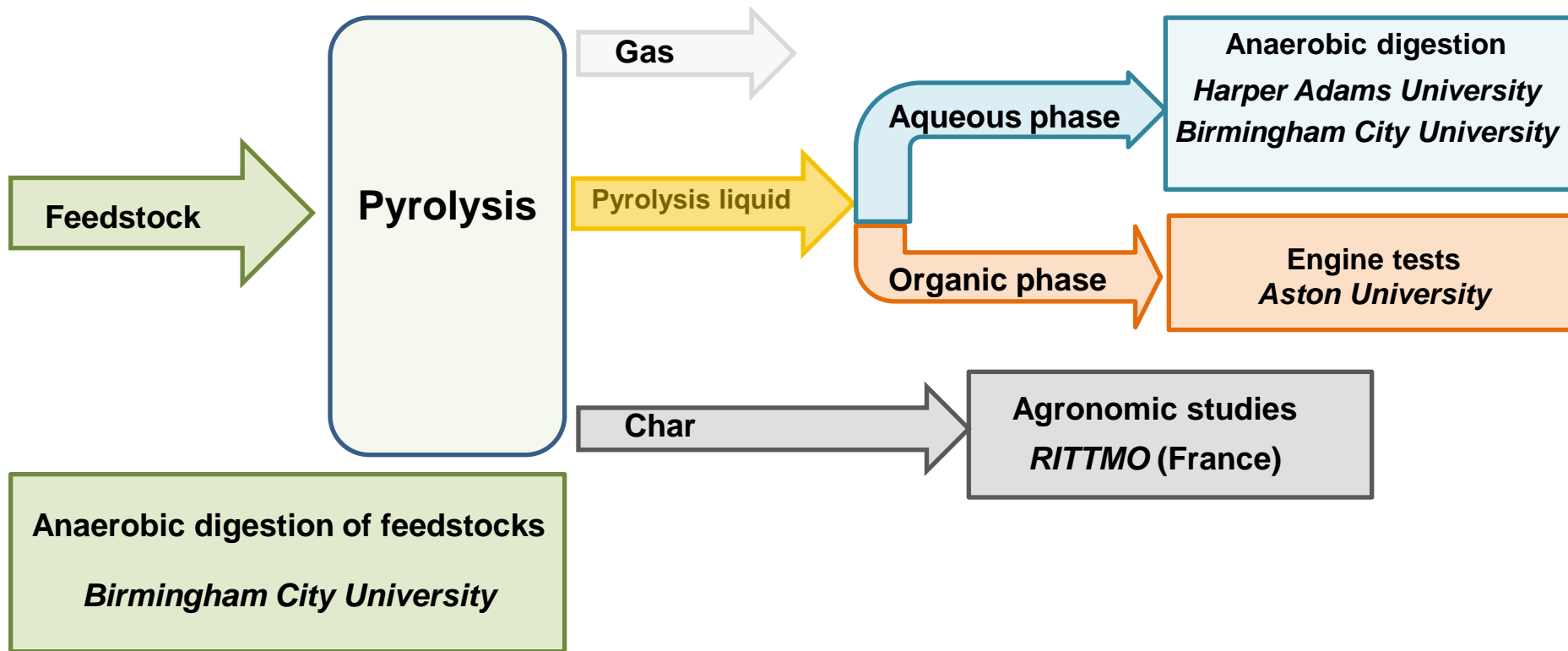

Feedstocks: provided by the project partners and analysed by EUBIA (Sweden)

*Kan hållbar energy ge tillväxt i Norrland?, 27th August 2015
Hotell Hallstaberget Sollefteå, Sweden*



BioenNW: Work Programme Technology Demonstrators: Pyrofabs – mobile testing units



Utilisation of the products



Agronomic studies of biochar on tomatoes and bananas.



Anaerobic digestion studies of the aqueous phase

*Kan hållbar energy ge tillväxt i Norrland?, 27th August 2015
Hotell Hallstaberget Sollefteå, Sweden*



BioenNW: Work Programme Technology Demonstrators: Pyrofabs – mobile testing units



Pyrolysis tests

BioenNW project partner	Feedstock tested (and acronym)
Sweden – Belgium	Forestry residues (FRBT)
France	Digestate from chicken litter and sawdust (DCLS)
Germany	Digestate from energy crops containing some slurry and manure (DSM)
Netherlands	Pig manure (PM)
United Kingdom	Digestate from arable crops (corn and green rye) (DAC)



BioenNW: Work Programme Technology Demonstrators: Pyrofabs – mobile testing units



Pyrolysis products

Forest residues

Digest.energy crops

Pig manure

Digest.chicken litter

Feedstocks

- MOISTURE
- VOLATILE
- FIXED CARB
- ASH

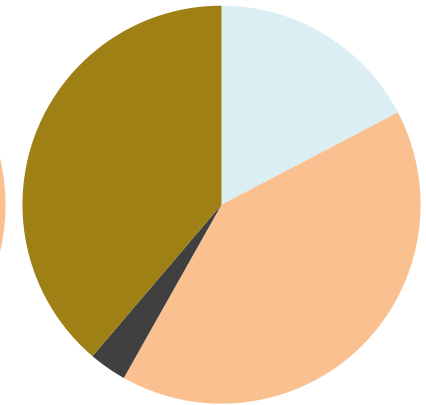
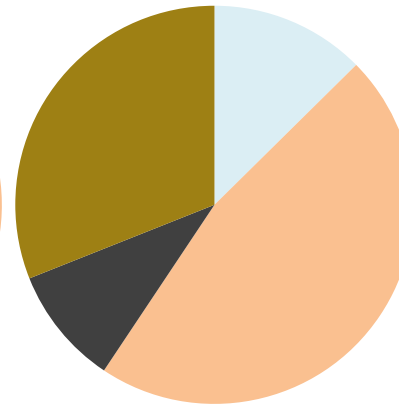
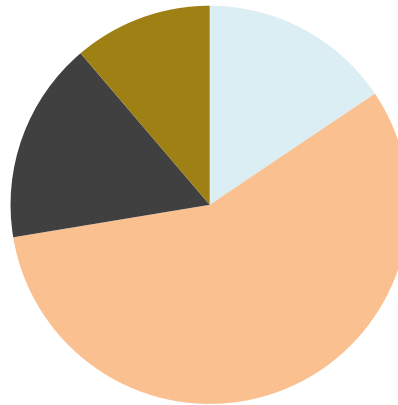
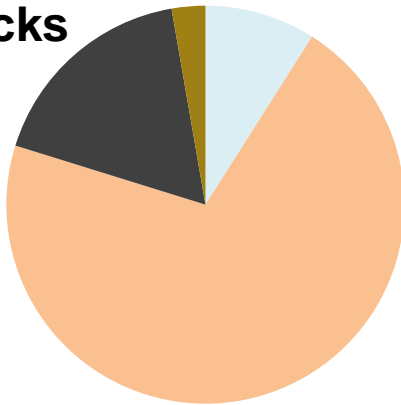

Products

- GAS
- AQUEOUS
- ORGANIC
- CHAR

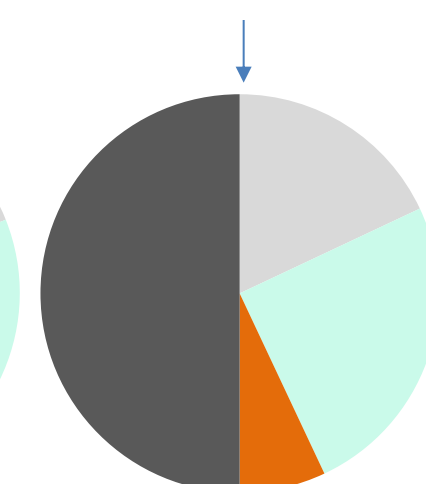
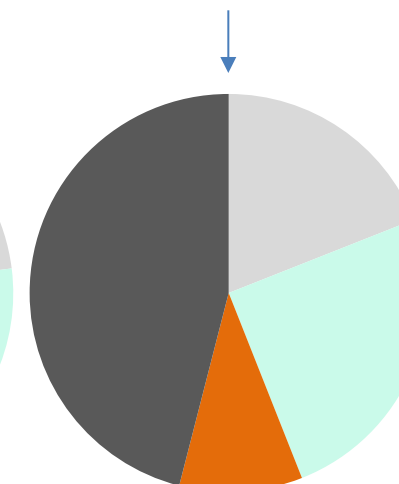
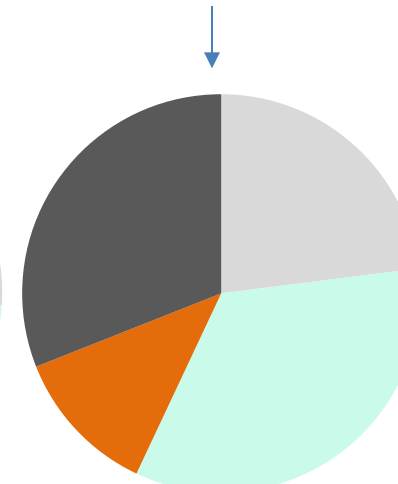
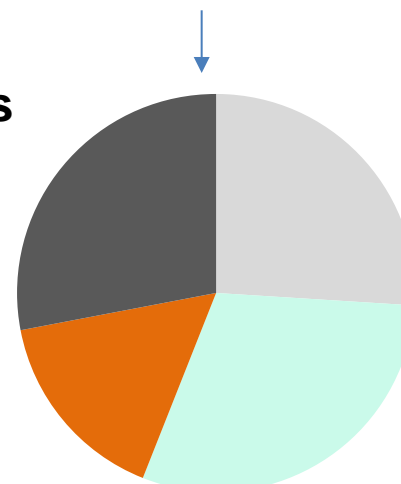



BioenNW: Work Programme Technology Demonstrators: Pyrofabs – mobile testing units



Properties of products

Averaged properties for the organic phase and the char

Feedstock	Organic phase		Char	
	High heating value	Viscosity	High heating value	Ash content
	(MJ/kg)	(cP)	(MJ/kg)	(% w/w)
Forestry residues	28.5	51.11	29.4	11.8
Digestate	25.8	120.59	22.2	33.8
Pig manure	23.7	299.46	10.5	61.6



BioenNW: Work Programme Technology Demonstrators: Pyrofabs – mobile testing units



Future tests

Project partner	Tests on site
	Feedstock
Sweden - Belgium	Forestry Residues
France	Food waste from restaurants around Les Mureaux
Germany	Digestate (mainly maize silage)
Netherlands	Pig manure



BioenNW – Delivering Bioenergy to North West Europe



- **Strategic Initiative**
- **Partnership**
- **Work Programme and Achievements**
- **Next Steps**



Next Steps: Testing



- *Testing more feedstocks, without being pelletised*
- *Testing different quenching liquids in the condensing system*
- *More agronomic studies of the char*
- *Testing more pyrolysis liquids in diesel engines*
- *Use of the biochar or gas to heat the reactor*
- *New applications for the aqueous phase*



Next Steps: Horizon 2020 and Interreg VB



- *Ready made network*
- *Stepping stone for future bids*
- *Opportunities to add value to current work and develop new proposals*
- *Robust partners from academia, public and private sector*
- *Common areas of work and interest*
- *Research placements and educational courses*
- *Commercialisation of technology*
- *Coverage: North West Europe*



Thank you for your attention!